



MINIMILL

Nut- und Formzirkularfräsen

groove milling by circular interpolation

Typ Z22

Vollradius

D min. 22 mm
t max. = 4.5

full radius

D min. 22 mm
t max. = 4.5

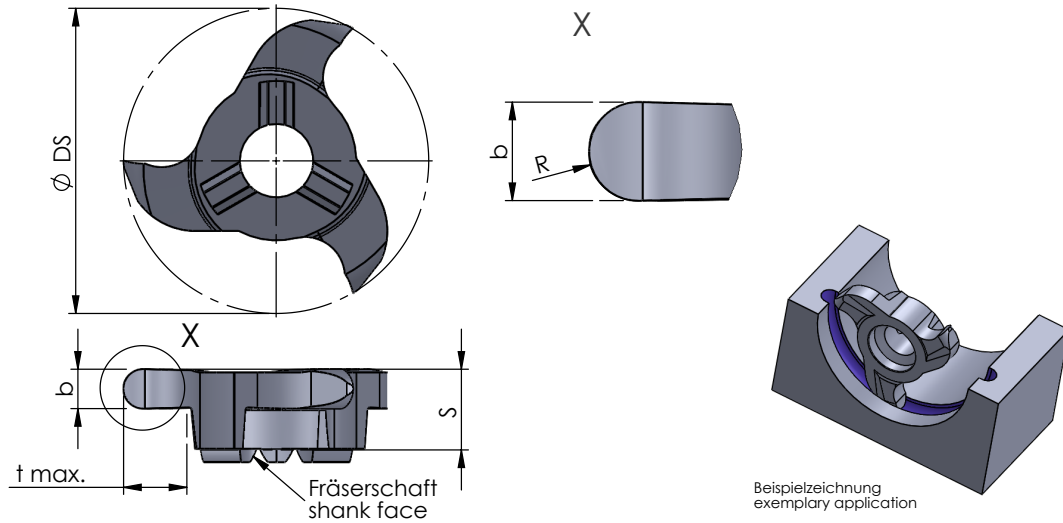

Abmessungen in mm

dimensions in mm

Bestellnummer part number												für Fräseschaft for toolholder type
	D min.	S	R	Ø DS	b +0.03	b (inch)	t max.	Zähnezahl number of teeth	K10F	AL41F	P18C	
Z22.0005.10	22	5.8	0.5	21.7	1.0		4.5	3		●		ZH22
Z22.0008.16	22	5.8	0.8	21.7	1.6		4.5	3		●		
Z22.0010.20	22	5.8	1.0	21.7	2.0		4.5	3	●	●		
Z22.0012.24	22	5.8	1.2	21.7	2.4		4.5	3		●		
Z22.0014.28	22	5.8	1.4	21.7	2.8		4.5	3		●		
Z22.0015.30	22	5.8	1.5	21.7	3.0		4.5	3		●		
Z22.U015.31	22	5.8	1.57	21.7	3.17	0.125"	4.5	3		●		
Z22.0020.40	22	5.8	2.0	21.7	4.0		4.5	3		●		
Z22.0022.44	22	5.8	2.2	21.7	4.4		4.5	3		●		
Z22.0025.50	22	5.8	2.5	21.7	5.0		4.5	3		●		

Weitere HM Sorten können Sie in der Sortenübersicht im Kapitel "Technische Hinweise" und der Preisliste finden.

Bestellbeispiel:
für Sorte AL41F:
Z22.0025.50/AL41F

More carbide grades you can find in the grades summary in the chapter "technical instructions" and in the price list.

order-example:
grade AL41F:
Z22.0025.50/AL41F