

# Z16

Vollradius

ab Bohrung Ø 16 mm

full radius

min. bore Ø from 16 mm

# MINIMILL

Nut- und Formzirkularfräsen

groove milling by circular interpolation

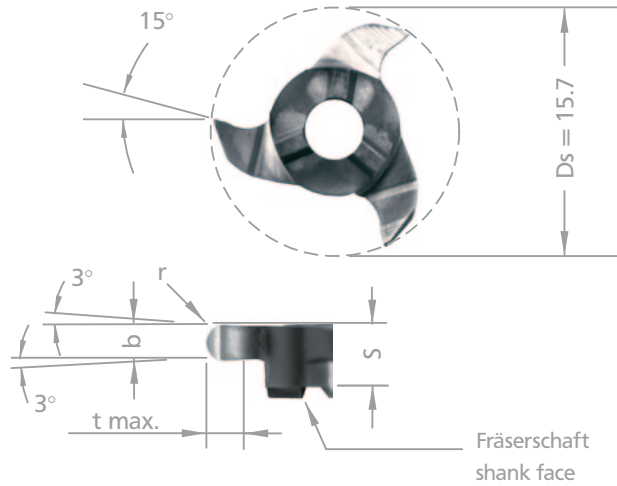

Abmessungen in mm

dimensions in mm



Bestellnummer  
part number

D min.

s

r

b +0.03

t max.

Zähnezahl  
number of teeth

für Frälerschaft  
(S. 265)  
for toolholder type  
(p. 265)

Standard HM Sorte  
standard carbide grade

Z16.0011.22

16

4.6

1.1

2.2

3.5

3

ZH14

AL41F (=TIALN)

HM Sorten siehe S. 370  
«Sortenübersicht» und Preisliste

Bestellbeispiel:  
für Sorte AL41F:  
Z16.0011.22/AL41F

carbide grades p. 370 see «grades  
summary» and according price list

order-example:  
grade AL41F:  
Z16.0011.22/AL41F